

AV-33025/1/2011-AT II  
Ministry of Civil Aviation  
Office of the Director General of Civil Aviation  
Opp. Safdarjung Airport, Aurobindo Marg

Dated 14<sup>th</sup> June 2011

**Sub: Limited Tender for conduct of online examination for issue of Pilot License**

The Central Examination Organisation, Office of the Director General of Civil Aviation, Ministry of Civil Aviation, invites technical & commercial bids for conducting online examination for granting Airline Transport Pilot License. Interested Organizations involved in or capable of undertaking this issue may send their bids in a sealed envelope.

Objective, scope of work, timeline, information to be furnished by the organization, evaluation criteria for selection and other relevant details have been laid down in the following pages of this document.

Bids shall be addressed to: Mr. P.Pathak, Director, CEO, R.K.Puram, East Block-III, New Delhi-66. The last date for receipt is 24<sup>th</sup> June 2011. Bids received after this date will not be considered. The bids received in time will be evaluated on the criteria fixed in the Tender Bid Document. Financial bid should be sent along with the technical bid but in a separate sealed envelope. No commercial information should be included in the technical bid. Financial bid of only those bidders who have qualified the technical bid will be opened. The sealed envelope should be marked as "Tender for conducting Online Exam for Issue of ATPL" and should include two separate sealed envelopes one each for technical bid and commercial bid. The same should be clearly indicated on each envelope.

(P. Pathak)  
Director (CEO)  
Office of the Director General of Civil Aviation  
Ministry of Civil Aviation  
Government of India  
Tel: 26185419

**Central Examination Organisation**  
**Office of the Director General of Civil Aviation**  
**Ministry of Civil Aviation**

**Notice Inviting Tender for**

Appointment of an Agency for conducting online examination for issue of Airline Transport Pilot License (ATPL)

**1. Introduction:**

1.0 Central Examination Organisation, Office of the Director General of Civil Aviation (DGCA) conducts written examinations for issue of licenses to Pilots, Aircraft Maintenance Engineers (AMEs) and Flight Dispatchers / Engineers. All examinations are written tests except for Airline Transport Pilot License which has an oral test also. Presently the examinations are paper driven. DGCA now proposes to initiate computer based test for ATPL license on a pilot basis in the four metro cities of Delhi, Mumbai, Kolkata and Chennai. Quotations are invited for appointment of an agency for conducting examination for ATPL in any of the ways indicated in sub-clause 2.1.

1.1 The tenderer should submit their bids in three envelopes.

**Envelope No. 1** - Shall contain signed copies of tender, Documents, duly filled Form - 1 required for technical evaluation as detailed in Annexure I and EMD of Rs.50000 in the form of a Demand Draft /Pay Order in favour of P.A.O, DGCA, Ministry of Civil Aviation, New Delhi payable at New Delhi. **The tender will not be considered if EMD is not submitted.** The envelope should be super scribed “**Technical Bid**”.

**Envelope No. 2** - Shall contain Price bid as per form -2 and shall be super scribed “**Financial Bid**” on the envelope. Price bids of only pre-qualified parties will be opened.

**Envelope No. 3** - Shall contain both Envelope No. 1 and Envelope No. 2.

All Envelopes should be properly sealed by Bidders and should be clearly super scribed with Envelope number and “**Tender for conducting Online Exam for Issue of ATPL**”

1.2 Late bids i.e., bids received after the specified date and time for receipt of bids shall not be considered.

1.3 The Earnest Money Deposit (EMD) should remain valid for a period of forty five days beyond the final bid validity period. EMD of unsuccessful bidders would be returned to them after the finalisation of the tender.

- 1.4 The successful bidder will be required to furnish **Performance Security of 10% of the contract value** in the form of Fixed Deposit Receipt/ Bank Guarantee from any Commercial Bank, Demand Draft/ Pay Order in favour of P.A.O, DGCA, Ministry of Civil Aviation, New Delhi payable at New Delhi within two days of receipt of the order. The Performance Security would be retained by DGCA till satisfactory completion of the work assigned and shall remain valid till ninety days of the completion of all contractual obligations.
- 1.5 The EMD would be returned to the successful bidder on receipt of Performance Security. No interest on Performance Security would be payable by DGCA under any circumstances.
- 1.6 Considering the confidentiality and sensitivity of the work involved, the bidders have to enclose a certificate along with the technical bid to the effect that it would not divulge any details pertaining to the examination to anybody without prior permission of DGCA and that it would take necessary preventive measures to ensure that nobody would come to know that the exam is being conducted by them. The agency will also have to certify that none of the relations of the personnel to be deployed for this work would appear for the exam to be conducted in July.

## **2. Scope of work**

- 2.1 The National Informatics Center (NIC) has developed software that includes all the pre-examination formalities like online application, allotting roll numbers, Exam Scheduling etc. in its first phase. The second phase covers development and administration of test modules and the third phase, processing the exam results. DGCA intends to use the software developed and managed by NIC. The application developed by NIC can be implemented in any of the following two modes. Bids may include separate quotations for both the modes.
  - 2.1.1 A localized Server based application where in each city/site multiple client systems in LAN are contacting the web server on the local host and carrying the transactions and data being managed on the local data base server system. The data shall be updated to the central server at defined schedules via the communication Leased Lines provided at the site. ( See the Diagram in Annexure – II)
  - 2.1.2 A secure web application where hundreds of clients from several sites/cities accessing the Central web server directly ( See the Diagram in Annexure – III)
- 2.2 DGCA would like the agency to provide the infrastructure required for testing like the space, servers, computers, UPS, generators, LAN/WAN of required speed, routers, Network Mgt S/W, Firewalls, and proxy servers etc.

- 2.3 The examination will be conducted in four cities for three days and two batches per day. There are in all six papers and duration of each paper varies from 90 minutes to 3 hours. It will be held in the last week of July 2011. The number of candidates appearing for the test in each batch would be approximately 225 each in Delhi and Mumbai, 90 in Kolkata and 135 in Chennai.
- 2.4 DGCA reserves the right to alter/ change the number of candidates appearing for the test in each batch at each centre by 30% of the number mentioned in sub-clause 2.3 above.
- 2.5 Agency shall provide the computers and the necessary infrastructure to conduct the examination at all the centres in either of the modes as mentioned at 2.1.
- 2.6 Agency shall ensure foolproof data security, data transfer and physical security inside venues.
- 2.7 Agency shall provide sufficiently decent and quiet space to conduct the test.
- 2.8 Agency shall provide sufficient environment and infrastructure so that the CEO shall conduct the exam in batches as detailed in para 2.3.
- 2.9 The Agency shall ensure that complete and comprehensive mock drill is carried out one day before the exam in the presence of representatives of NIC and DGCA.
- 2.10 The LAN set up shall be virus free and fire-walled. The terminals and the servers including the backups shall also be virus free.
- 2.11 Hardware, Network and other requirements are as specified below:

2.11.1 **Servers :** ( two servers are required at each site Covering 2.1.1 )

**SERVER – A (Local Web Server):** "High End Server Pedestal type 2P 1U" :  
2 \* Intel/AMD x86 processors(Quad Core ) with at least 2.3 Ghz speed with SPEC Average of 86 plus/minus 2; 8 GB DDR-533 MHz SDRAM upgrade able to 32 GB ( Min. 8 DIMM Slots); 2\* 146 GB HS FC-AL/SAS HDD (10K or higher RPM); Integrated SAS /FC-AL Controller with RAID 0,1; Integrated Dual port 10/100/1000 Mbps; Internal DVD drive; Internal DVD drive; One single port HBA for FC-4 connectivity, supporting 1/2/4 Gbps with 5 metre multimode LC-LC cable; Redundant and hot swappable Power Supply; Dedicated port for out of band remote management; OS Support : OS - RHEL server s/w version 5.4 or above. The server will have the Static (Fixed) IP addresses at each site.

**SERVER – B(Local RDBMS Server):** Pedestal Type; 2 \* Quad Core x86 Intel/AMD Processors with at least 2.3 Ghz speed with SPEC Average of 86 plus/minus 2; 16 GB of DDR-II 533 Mhz or higher SDRAM memory with ECC expandable up to 32 GB (8 DIMM Slots); 2 \* 146GB HS SAS ( 10K RPM or higher) disks in a RAID 1 configuration on a hardware RAID controller; Dual Port Gigabit Ethernet; Dual port HBA along with all the necessary components and two no. of 5 meter Optical fiber (multimode) LC to LC cables; OS Support : Windows 2003 with adequate and latest sp's and patches. SQL Server 2005 (RDBMS) on Server B with adequate and latest SP's. The server will have the Static (Fixed) IP addresses at each site.

2.11.2 Network based Laser A4 size Color Printer (Minimum of 16 PPM) connected in LAN with the server and clients ( Covering 2.1.1 )

2.11.3 One Leased Line from the ISP with 4Mbps minimum at each site( Covering 2.1.1 )

2.11.4 CAT-6 UTP LAN ( Covering 2.1.1 and 2.1.2 )

2.11.5 PIV Client systems 32 bit ( Covering 2.1.1 and 2.1.2 )

Desktop Mid Range(Windows OS) Intel Core 2 Duo E8400 ( 3 GHz speed, 1333 MHz FSB & 6 Mb L2 Cache) or higher; Gigabit Ethernet Controller; 2\*2 GB DDR2 800MHz or higher; 250 GB SATA or higher; Small form factor system chassis of volume less than 14 liter(+5%) with suitable power supply; 104 keys OEM keyboard & optical scroll Mouse with mouse pad; TCO 03 Certified 19 or higher TFT; Windows 7 professional, with all necessary plugins & Drivers in CD Media; ANTIVIRUS: Latest version

2.11.6 Sufficient UPS system ( Covering 2.1.1 and 2.1.2 )

- 2.11.7 Four-port Gigabit Ethernet Router or L3 Switch at each of the exam site. ( Covering 2.1.1 and 2.1.2 )
- 2.11.8 Twenty-four-port Gigabit Ethernet switches for each group of twenty (20) clients connected at the exam site LAN and two additional switches of the similar config at each site of the exam (Covering Four-port Gigabit Ethernet Router or L3 Switch at each of the exam site. ( Covering 2.1.1 and 2.1.2 )
- 2.11.9 Services of the Truly Qualified System Administrator, Database Administrator, System integrator and Network manager (one each) at each site. ( Covering 2.1.1 )
- 2.11.10 Services of the Truly Qualified System integrator and Network manager (one each) at each site. ( Covering 2.1.2 )
- 2.11.11 Two Leased Lines of minimum 10 Mbps speed from two different ISPs connected between the Exam site and the respective NIC centre at the state unit in the city where site of exam is located. There shall be two Public IP addresses made available by these two ISPs each (Covering 2.1.2 )
- 2.11.12 Security enablement / VLAN enablement will be as per the directions of NIC
- 2.11.13 Sharing the site for network integration with NIC for a Week time for security, proper hand shaking and actual s/w testing before the exam conducted live at each site.

### **3 Time frame**

- 3.1 Time limit for receipt of bids: 24<sup>th</sup> June, 2011 at 5.30 pm. (Late bids received after this time limit shall not be entertained.)
- 3.2 Evaluation of Commercial Bids: 3 PM on 30<sup>th</sup> June 2011

3.3 The indicative implementation plan for this project is provided below.

Step #	Step Description	Weeks	Tentative Dates
1.	Finalizing the project plan	Within 1 week of Placing the Order	By July, 7
2.	Testing at All Centers	Within 10 days	By July, 17
3.	Go Live		Last week of July 2011 (Proposed)

**Note:**

The project timelines are based on certain assumptions and may change marginally

## 4 Procedure of Evaluation and Selection

4.1 DGCA reserves the sole right to accept or reject any or all bids which is incomplete or has been received after the appointed time and date or does not satisfy the prequalification criteria specified here under, without assigning any reasons there for. The technical bids shall not be considered for technical evaluation unless it is accompanied by the following:

- i. Submission of Earnest Money Deposit of Rs 50,000.
- ii. Submission of Work Orders as per Sl. No. 8 in Form-1 on Particulars i.e., Copy of work order wherein the party/ company had administered online test modules at all-India levels including setting up of the exam centers at various locations

The evaluators of the technical bid shall not have access to the financial bid till technical evaluation is completed. The technical bids shall be opened by a Technical Evaluation Committee (TEC) constituted for the purpose. Technical evaluation shall be done keeping in view the following parameters:

S. No	Parameter
A	<b>Past experience in work of similar nature</b> Should have executed minimum of five (5) projects of similar nature
B	<b>Average turnover of the Agency in the last three financial years (2008-09, 2009-10, 2010-11) in online</b>

S. No	Parameter
	<b>examination Rs 4 crores and an overall turn-over of Rs 10 crores</b>
C	Compliance with ISO 27001 (Former BS7799-2) - desirable.
D	<b>Infrastructure and other details</b> Office, hardware and software resources Personnel including skills and competence in all the four metro cities(namely Mumbai, Delhi, Chennai & Kolkata)
E	Party should have PAN and Service Tax Number.
F	Party should be able to furnish a copy of the latest Income Tax Return.

Bids which are not otherwise rejected for the reasons indicated above will be evaluated on the basis of cost.

- 4.2 The **financial bid** should contain a quote fee for the assignment in Indian Rupees. The rates may be quoted **per candidate per hour** basis. Agency shall include in its price all taxes and other costs while quoting for the tender, in **“Form-2: Price Offer” to be kept in Envelop No. 2. Actual payment will be on the basis of number of candidates appearing for the exam.** Income Tax will be deducted at source from the bills as applicable. The Agency needs to furnish its PAN number.
- 4.3 Financial bids of only those bidders who qualify the technical criteria will be opened. Of these the one quoting the lowest cost will be awarded the contract provided all other requirements are fulfilled.
- 4.4 DGCA shall have right to accept or reject any or all tenders without assigning any reasons thereof.

## 5 Payment

- 5.1 25% of the payment will be made on successful testing of all Centres by the CEO of DGCA. Remaining 75% of the payment will be made on satisfactory completion of the task assigned.

## 6 Conditions of the Tender :

- 6.1 The Agency will ensure complete and trouble free administration of Online Tests & invigilation and also security & integrity of data all the time. Leakage of secured information in any form will be considered as a breach of contract and a cognizable offence.



- 6.2 DGCA reserves its right to terminate the contract for any reason at its absolute discretion.
- 6.3 DGCA reserves the right to claim damages, of which DGCA shall be the sole judge, in respect of delays directly or indirectly due to the failure/default on the part of Agency in carrying out the responsibilities/duties efficiently and promptly.
- 6.4 The submission of a tender by an Agency implies that he has read these instructions and has made himself aware of the scope of work and the conditions of the contract and DGCA will not therefore, pay any extra charges on any account in case the Agency finds later on to have misjudged the conditions.
- 6.5 Any act on part of the Agency or his employees which will be prejudicial to the interest of the DGCA shall be considered as grave breach of the condition of the contract and shall render the contract liable for immediate termination. Loss due to any act on part of the Agency will be entirely its responsibility.
- 6.6 The Agency shall engage adequate number of qualified and experienced persons /its own employees to carry out the assignment under contract successfully.
- 6.7 The workers employed by the Agency to perform the contract, shall be the employees of the Agency and the Agency alone shall be liable to pay the wages and all other payments as may be due to the workers and DGCA shall in no way be liable for the same. The Agency shall also comply with all the provisions under the laws of the land pertaining to its workers and their employment for the purpose of performing the contract if so awarded against this tender and the Agency shall also indemnify DGCA for any claims whatsoever made by such workers against DGCA in that behalf.
- 6.8 DGCA shall not be responsible for death, disablement, injury, accident to Agency's employees, which may arise out of and in the course of their duties with the Agency. DGCA shall not be liable to pay any damages or compensation to the Agency's employees. The same are to be paid by the Agency as per the provisions of Law.
- 6.9 Force Majeure: The agency shall not be responsible for any failure to perform due to causes beyond its reasonable control including but not limited to acts of God, fire, flood, war riots, embargoes, strikes, lockouts, act of any Government authority, accidents or disruption or operations arising from causes not attributable to any malafide acts of firm.
- 6.10 The jurisdiction of court for redressal of any dispute arising out of this contract shall be that of the Delhi Courts.

## **7 Statutory Obligations**

- 7.1 The Agency shall comply with all the Central, State and Municipal Laws & Rules and shall be solely responsible for the implementation of the provisions of the various Labour Laws and Rules there under and other statutory regulations, rules that are in force.

## **8 Penalty Clause:**

8.1 If the Agency fails or delays to fulfil the obligations in the execution of work to the entire satisfaction of DGCA, DGCA reserves the right to terminate the contract and forfeit the performance security by way of en-cashing the demand draft/pay order/Fixed Deposit receipts or invoking the Bank Guarantee as the case may be, without prejudice to DGCA's further right to claim compensation from the Agency as a result of its failure or delay to fulfil the obligations.

## **Annexure – I**

Tenders are invited from experienced and reputed firms in the field of conducting online recruitment test. The profile of the bidder ought to be a well-established firm with a team of experienced staff, all India network, skilled manpower etc. The bidder should have experience to undertake works of similar type and magnitude.

### **In Support of above, party should submit following documents/ information:**

1. Profile of the organization.
2. Details of Networking to undertake fully online test.
3. List of clients including PSUs, Educational institutions / Central Government /State Government etc. where similar jobs are executed in past 3 years with copy of self-attested work orders.
4. List of test centres & Infrastructure facilities available on All India Basis.
5. Confirmation of testing system compliant with ISO 27001.
6. Copy of Annual Report for last 3 years.
7. Latest Income Tax return submission copy.
8. Copy of PAN & Service tax registration number.
9. Certificate by the authorized signatory that all the terms and conditions of the bid are acceptable to the bidder.
10. Sufficient proof to show the turn-over from the online exam and overall turn-over to the satisfaction of the DGCA.

## **FORM-1: PARTICULARS**

**Please fill in the form in the format given below.**

- 1.** Name of the Firm
- 2.** Address of the Firm
- 3.** Contact Person (s) with mobile number (s)
- 4.** Email address
- 5.** Telephone numbers
- 6.** Details of EMD (Mention DD number, bank, amount)
- 7.** ISO 27001 Certification for Online Test Confidentiality: Yes/No  
If yes attach copy of the same
- 8.** Whether you have administered the online test modules at all-India levels including setting up of the exam centres at various locations: Yes/No  
If Yes, attach copy of Work Order
- 9.** Whether enclosed Annual Reports of Past three years: Yes/No
- 10** Whether submitted Income Tax submission copy: Yes / No
- 11** Whether submitted PAN copy: Yes / No
- 12** Whether submitted Service Tax Registration Number: Yes / No

**Note:** a) In case you have a consolidated work order which clearly spells out all the activities mentioned above (Sl. No. 8), you may attach the same.  
b) Non-submission of EMD and Work orders (Sr No 8) will disqualify you and in that case, your price bid shall not be opened.

## FORM-2: Price Offer

**Per candidate per hour** charges for administering the online test at the four metro cities including setting up of the examination centers:

**Amount in INR: -----**

Grand Total in INR:----- (Inclusive of all taxes)

**Note:** Number of candidates is expected to be around 4000.

Date

Company seal

Signature

## Annexure – II

General Network diagram depicting connectivity for conducting exams for pilots / AMEs using VIMANIC at any site in the country for a batch of 100 candidates

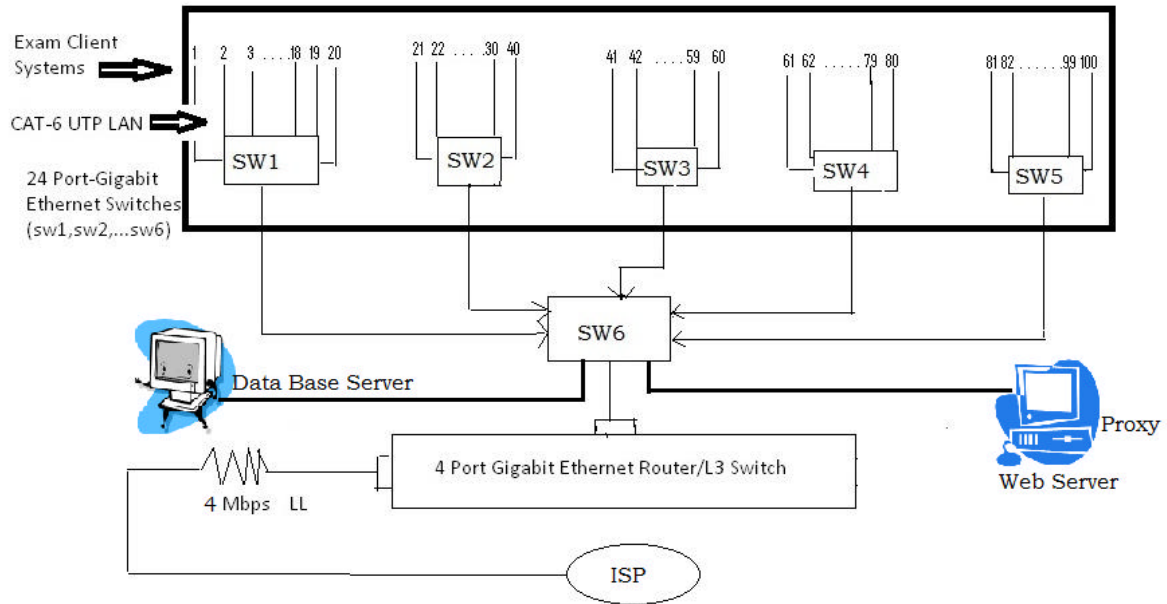

**ANNEXURE - III**

General Network diagram depicting connectivity for conducting exams for pilots / AMEs using VIMANIC at any site in the country for each 100 candidates

